

Crimp-Rast-Stiftleisten RM 4,20mm, gerade / gewinkelt - mit Befestigungsoptionen

Friction Lock Pin Headers 4.20mm Pitch, Straight / Right-Angled - with Mounting Options

Technische Daten / Technical Data

Isolierkörper	Thermoplast, UL94 V-2 (-HT: UL94 V-0)
Insulator	Thermoplastic, UL94 V-2 (-HT: UL94 V-0)
Kontaktmaterial	Kupferlegierung
Contact Material	Copper alloy
Kontaktoberfläche	Lt. Oberflächenoptionen, über Ni
Contact Surface	Acc. to options (see below), over Ni
Durchgangswiderstand	< 20 mΩ
Contact Resistance	< 20 mΩ
Isolationswiderstand	> 1000 MΩ
Insulation Resistance	> 1000 MΩ
Spannungsfestigkeit	1,5 kV AC
Test Voltage	1.5 kV AC
Nennspannung	600 V AC/DC
Voltage Rating	600 V AC/DC
Nennstrom	7 A AC/DC
Current Rating	7 A AC/DC
Temperaturbereich	-25 °C ... +85 °C
Temperature Range	-25 °C ... +85 °C
Verarbeitung	Wellenlötverfahren (-HT: Reflow-Lötverfahren)
Processing	Wave soldering (-HT: Reflow soldering)

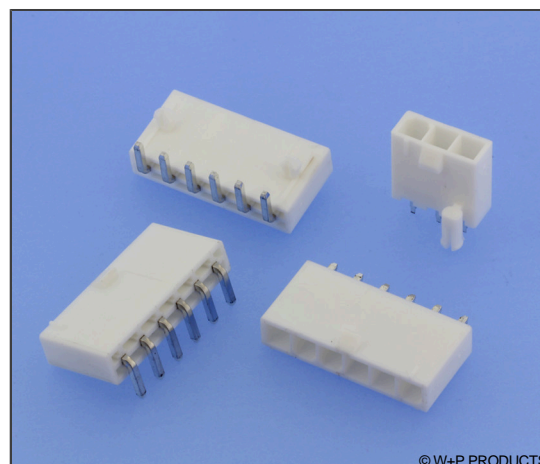

© W+P PRODUCTS

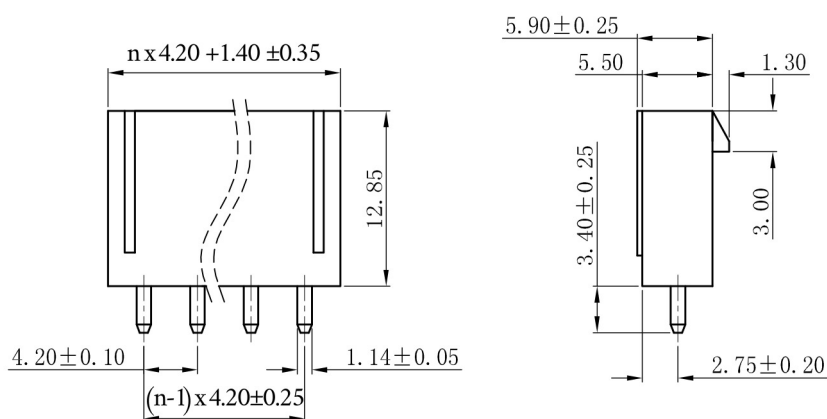
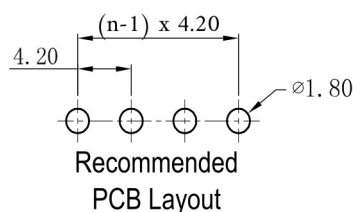
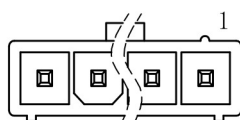

Series	Contacts*	Type	Plating	Material*
547	04 02-06 Einreihig Single row	07 07 Stiftleiste gerade, ohne Kragen Pin header straight, w/o collar	50 50 Sn	.. HT Für Reflow-Löten For reflow soldering

547

Crimp-Rast-Stiftleisten RM 4,20mm, gerade / gewinkelt - mit Befestigungsoptionen Friction Lock Pin Headers 4.20mm Pitch, Straight / Right-Angled - with Mounting Options

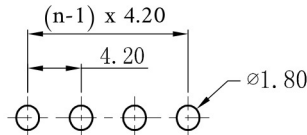
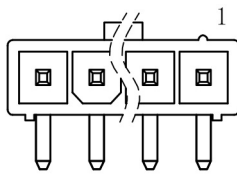

Recommended
PCB Layout

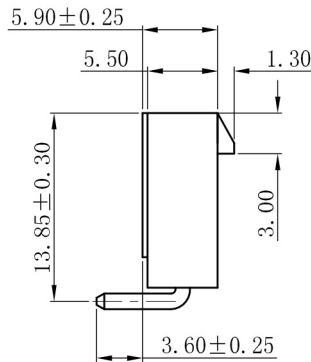
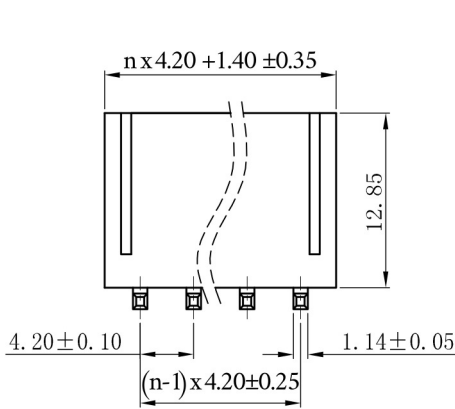

Series

547

Contacts*

04

02-06 Einreihig
Single row

Type

08

08 Stiftleiste gewinkelt, ohne Kragen
Pin header right-angled, w/o collar

Plating

50

50 Sn

Material*

..

HT Für Reflow-Löten
For reflow soldering

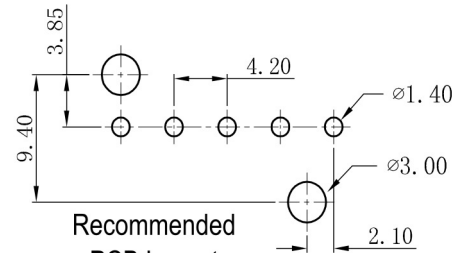
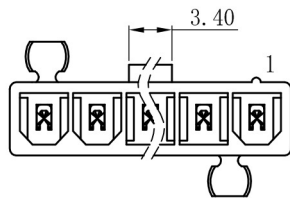

Recommended
PCB Layout

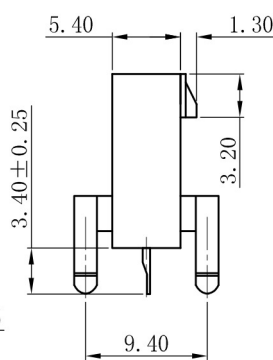
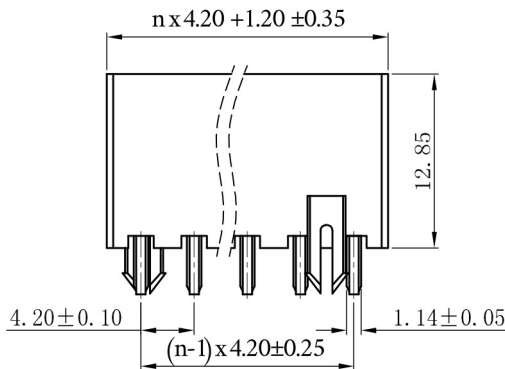

Series

547

Contacts*

05

03-06 Einreihig
Single row

Type

12

12 Stiftleiste gerade mit Rastclips
Pin header straight with rast clips

Plating

50

50 Sn

Material*

..

HT Für Reflow-Löten
For reflow soldering

Crimp-Rast-Stiftleisten RM 4,20mm, gerade / gewinkelt - mit Befestigungsoptionen Friction Lock Pin Headers 4.20mm Pitch, Straight / Right-Angled - with Mounting Options

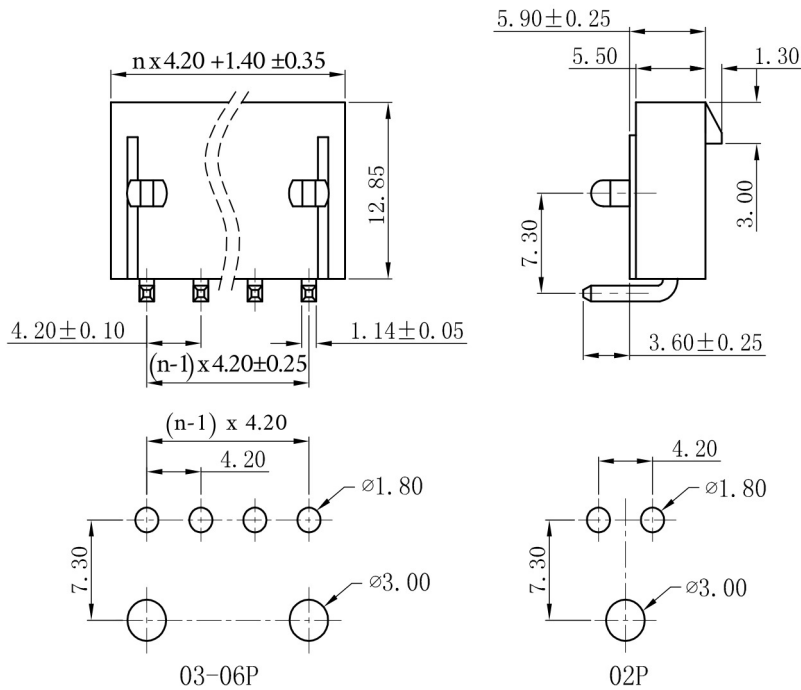
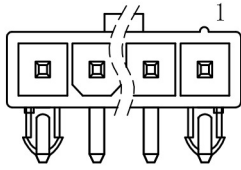

Series

547

Contacts*

04

02-06 Einreihig
Single row

Type*

10

10 Stiftleiste gewinkelt mit Rastclips
Pin header right-angled with rast clips

Plating

50

50 Sn

Material*

..

HT Für Reflow-Löten
For reflow soldering

* Dies ist ein **Bestellbeispiel** -
bitte durch Ihre Spezifikationen ersetzen.
* This is an **order example** -
please replace by your specifications.