

Wannenstifflisten mit Verriegelung RM 1,27mm, gerade/gewinkelt Box Headers with Latches, 1.27mm Pitch, Straight/Right-Angled

Technische Daten / Technical Data

Isolierkörper	Thermoplast, nach UL94 V-0
Insulator	Thermoplastic, rated UL94 V-0
Kontaktmaterial	Kupferlegierung
Contact Material	Copper alloy
Kontaktfläche	Lt. Oberflächenoptionen, über Ni
Contact Surface	Acc. to options (see below), over Ni
Durchgangswiderstand	< 20 mΩ
Contact Resistance	< 20 mΩ
Isolationswiderstand	> 1000 MΩ
Insulation Resistance	> 1000 MΩ
Spannungsfestigkeit	300 V AC
Test Voltage	300 V AC
Nennstrom	1 A
Current Rating	1 A
Temperaturbereich	-40 °C ... +105 °C
Temperature Range	-40 °C ... +105 °C
Verarbeitung	Wellen- oder Reflow-Lötverfahren
Processing	Wave or reflow soldering

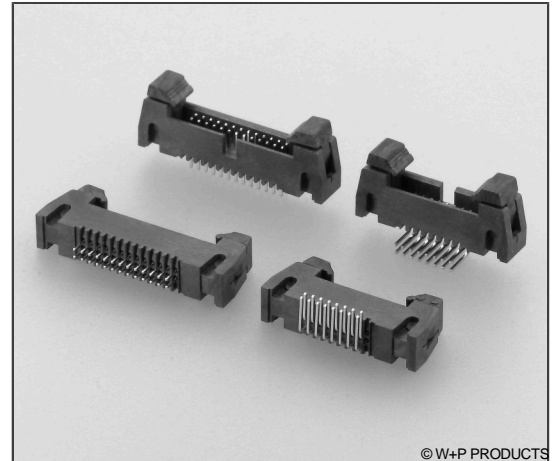

© W+P PRODUCTS

Passende Gegenstecker:
Mates with Connectors:
376

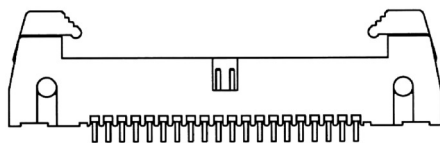
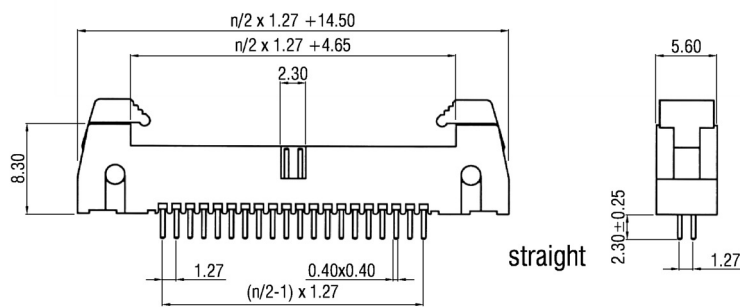

right-angled

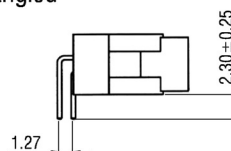
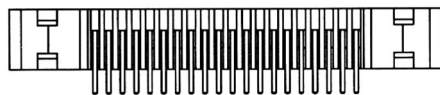

Rcm. PCB Layout

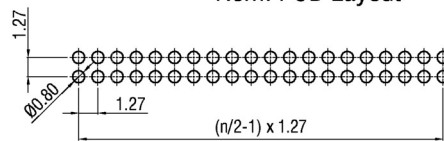

Series

337

Contacts*

12

06/10/12/14/16/
20/26/30/34/40/
44/50/60/68

Type*

1

1 Gerade
Straight
2 Gewinkelt
Right-angled

Plating*

00

00 Vergoldet
Gold plated

* Dies ist ein **Bestellbeispiel** -
bitte durch Ihre Spezifikationen ersetzen.
* This is an **order example** -
please replace by your specifications.

Informationen zum Reflow-Lötverfahren Reflow Soldering Information

Reflow-Lötempfehlung für kurze Lötzeiten

Die Bauteile sollten gemäß folgendem Temperatur-Profil in Anlehnung an die IPC/JEDEC J-STD-020C für bleifreies Löten im Reflow-Verfahren verarbeitet werden (Maximalwerte).

Profileigenschaft	Kennwert
Temperatur Minimum T_{Smin}	150 °C
Temperatur Maximum T_{Smax}	200 °C
Dauer $T_{Smin} - T_{Smax}$	60 – 180s
Temperatur Lötbereich T_L	217 °C
Verweildauer oberhalb T_L	60 – 180s
Ramp-Up Rate $T_{Smax} - T_P$	max. 3 °C / s
Höchsttemperatur T_P	260±5 °C
Dauer Höchsttemperatur	20 – 40s
Ramp-Down Rate $T_{Pmax} - T_{Smin}$	6 °C / s
Dauer 25 °C – Höchsttemperatur T_P	max. 8m

Reflow Soldering Recommendation For Shorter Peak Times

Items should be soldered according to IPC/JEDEC J-STD-020C temperature profile for leadfree reflow soldering (maximum values).

Profile Feature	Key Values
Minimum Temperature T_{Smin}	150 °C
Maximum Temperatur T_{Smax}	200 °C
Duration $T_{Smin} - T_{Smax}$	60 – 180s
Soldering Range Temperature T_L	217 °C
Duration above T_L	60 – 180s
Ramp-Up Rate $T_{Smax} - T_P$	max. 3 °C / s
Peak Temperature T_P	260±5 °C
Duration Peak Temperature	20 – 40s
Ramp-Down Rate $T_{Pmax} - T_{Smin}$	6 °C / s
Duration 25°C - Peak Temp. T_P	max. 8min

