

Technische Daten / Technical Data:

Isolierkörper	Thermoplastischer Kunststoff, nach UL94V0
Insulator	Thermoplastic, rated UL94V0
Gehäuse	Edelstahl
Shell	Stainless Steel
Kontaktmaterial	Phosphorbronze
Contact Material	Phosphor Bronze
Kontaktoberfläche	Gold über Nickel (siehe Optionen unten)
Contact Surface	gold over nickel (see options below)
Oberfläche Lötanschluß	Zinn über Nickel
Plating Solder Side	tin plated over nickel
Lötbarkeit	IEC512-12A
Solderability	IEC512-12A
Durchgangswiderstand	≤ 30 mOhm
Contact Resistance	≤ 30 mOhm
Isolationswiderstand	> 5x10 ⁸ Ohm
Insulation Resistance	> 5x10 ⁸ Ohm
Spannungsfestigkeit	500 V _{AC}
Test Voltage	500 V _{AC}
Nennstrom	1 A
Current Rating	1 A
Nennspannung	30 V _{AC/DC}
Voltage Rating	30 V _{AC/DC}
Temperaturbereich	-40°C...+105°C
Temperature Range	-40°C...+105°C
Verarbeitung	Reflow-Lötverfahren; weitere Informationen in Kapitel T
Processing	Reflow-Soldering, further informations in chapter T

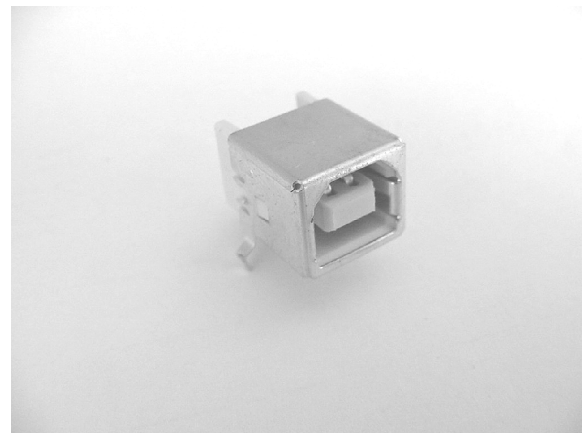
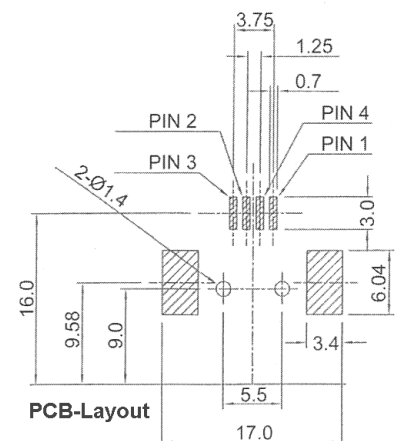
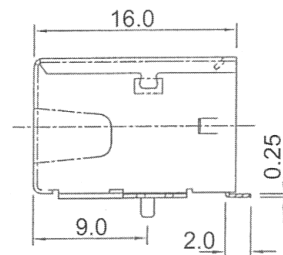
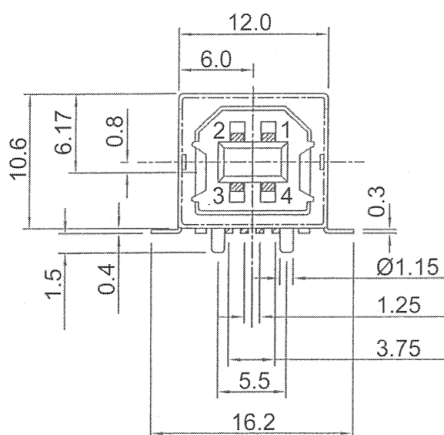

© W+P PRODUCTS

**Series**

8232

Colour*

20

10 = schwarz
black
20 = beige
ivory

Plating*

60

60 = sel. Au / Sn
80 = sel. Au 0,75 µm / Sn

(* Bestellbeispiel - Bitte durch Ihre Spezifikationen ersetzen.)

* Order example - To be replaced by your specifications.)

Informationen zum Reflow-Lötverfahren

Reflow-Soldering Informations

Reflow-Lötverfahren Reflow-Soldering

Bauteile sollten gemäß folgendem Temperatur-Profil in Anlehnung an die IPC/JEDEC J-STD-020C für bleifreies Lötten im Reflowverfahren verarbeitet werden (Maximalwerte):

Profil Eigenschaft	Bleifreies Lötten
Durchschnitts-Ramp-Up Rate ($T_{s_{max}}$ to T_p)	3 °C / Sek. Max.
Vorheizen - Temperatur Min ($T_{s_{min}}$) - Temperatur Max ($T_{s_{max}}$) - Zeit ($t_{s_{min}}$ auf $t_{s_{max}}$)	150°C 200°C 60-180 Sekunden
Verbleiben oberhalb: - Temperatur (T_L) - Zeit (t_L)	217°C 60-150 Sekunden
Peak/Klassifizierung Temperatur (T_p)	260°C +/- 5°C
Zeit innerhalb von 5°C um die Peak-Temperatur (t_p)	20-40 Sekunden
Ramp-Down Rate	6°C / Sekunde max.
Zeit von 25°C bis zur Peak-Temperatur	8 Minuten max.

© W+P PRODUCTS

Items should be soldered according to IPC/JEDEC J-STD-020C temperature-profile for leadfree reflow-soldering (maximum values):

Profile Feature	PB-Free assembly
Average Ramp-Up Rate ($T_{s_{max}}$ to T_p)	3 °C / second max.
Preheat - Temperature Min ($T_{s_{min}}$) - Temperature Max ($T_{s_{max}}$) - Time ($t_{s_{min}}$ to $t_{s_{max}}$)	150°C 200°C 60-180 seconds
Time maintained above: - Temperature (T_L) - Time (t_L)	217°C 60-150 seconds
Peak/Classification Temperature (T_p)	260°C +/- 5°C
Time within 5°C of actual Peak Temperature (t_p)	20-40 seconds
Ramp-Down Rate	6°C / second max.
Time 25°C to Peak Temperature	8 minutes max.

Empfohlenes Reflow-Lötprofil:

Recommended Reflow-Soldering profile:



T