

# 744

## Buchsenleisten - 2-reihig - RM 2,00 mm - durchsteckbar

Economy Female Header - Double Row - Pitch 2,00 mm - Dual Entry

### Technische Daten / Technical Data:

Isolierkörper	Thermoplastischer Kunststoff, nach UL94V0
Insulator	Thermoplastic, rated UL94V0
Kontaktmaterial	Kontakt CuZn 30
Contact Material	Contact CuZn 30
Kontaktfläche	lt. Oberflächenoptionen, über Ni (1,3-2,5 µm)
Contact Surface	acc. to options (see below), over Ni (1,3-2,5 µm)
Lötbarkeit	IEC512-12A
Solderability	IEC512-12A
Durchgangswiderstand	≤ 20 mOhm
Contact Resistance	≤ 20 mOhm
Isolationswiderstand	> 10 <sup>9</sup> Ohm
Insulation Resistance	> 10 <sup>9</sup> Ohm
Spannungsfestigkeit	500 V <sub>DC</sub>
Test Voltage	500 V <sub>DC</sub>
Nennstrom	1 A
Current Rating	1 A
Temperaturbereich	-40°C...+105°C
Temperature Range	-40°C...+105°C
Verarbeitung	Reflow-Lötverfahren; weitere Informationen in Kapitel T
Processing	Reflow-Soldering, further informations in chapter T

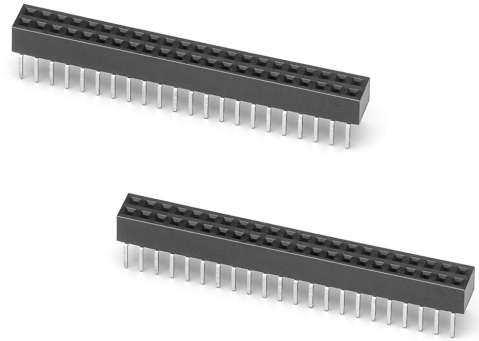

© W+P PRODUCTS

B

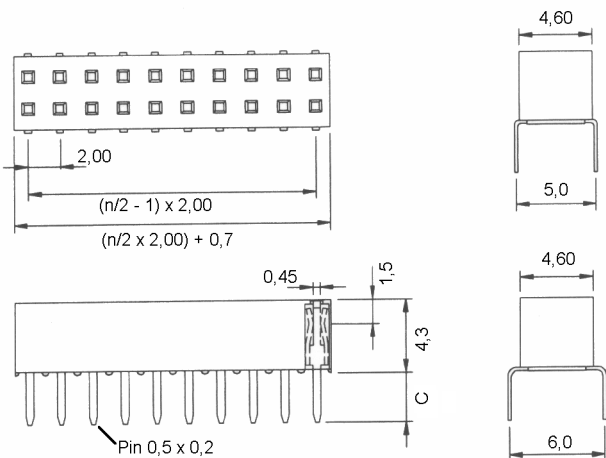

n = Anzahl Kontakte  
n = No. of Contacts

### PCB-Layout

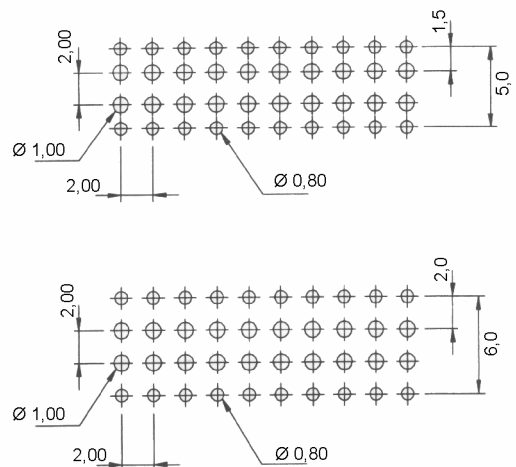

04-80-pol. zweireihig  
double row

1 = 5,0 mm / C = 3,6 mm  
2 = 6,0 mm / C = 3,0 mm

00 = vergoldet  
gold plated  
50 = verzinkt  
tin plated

(\* Bestellbeispiel - Bitte durch Ihre Spezifikationen ersetzen.  
\* Order example - To be replaced by your specifications.)

TEL.: +49 5223 98507-0  
FAX : +49 5223 98507-50

**W+P PRODUCTS**

E-MAIL: sales@wpro.com  
INTERNET: www.wpro.com

# Informationen zum Reflow-Lötverfahren

## Reflow-Soldering Informations

### Reflow-Lötverfahren Reflow-Soldering

Bauteile sollten gemäß folgendem Temperatur-Profil in Anlehnung an die IPC/JEDEC J-STD-020C für bleifreies Lötten im Reflowverfahren verarbeitet werden (Maximalwerte):

Profil Eigenschaft	Bleifreies Lötten
Durchschnitts-Ramp-Up Rate ( $T_{s_{max}}$ to $T_p$ )	3 °C / Sek. Max.
Vorheizen - Temperatur Min ( $T_{s_{min}}$ ) - Temperatur Max ( $T_{s_{max}}$ ) - Zeit ( $t_{s_{min}}$ auf $t_{s_{max}}$ )	150°C 200°C 60-180 Sekunden
Verbleiben oberhalb: - Temperatur ( $T_L$ ) - Zeit ( $t_L$ )	217°C 60-150 Sekunden
Peak/Klassifizierung Temperatur ( $T_p$ )	260°C +/- 5°C
Zeit innerhalb von 5°C um die Peak-Temperatur ( $t_p$ )	20-40 Sekunden
Ramp-Down Rate	6°C / Sekunde max.
Zeit von 25°C bis zur Peak-Temperatur	8 Minuten max.

© W+P PRODUCTS

*Items should be soldered according to IPC/JEDEC J-STD-020C temperature-profile for leadfree reflow-soldering (maximum values):*

Profile Feature	PB-Free assembly
Average Ramp-Up Rate ( $T_{s_{max}}$ to $T_p$ )	3 °C / second max.
Preheat - Temperature Min ( $T_{s_{min}}$ ) - Temperature Max ( $T_{s_{max}}$ ) - Time ( $t_{s_{min}}$ to $t_{s_{max}}$ )	150°C 200°C 60-180 seconds
Time maintained above: - Temperature ( $T_L$ ) - Time ( $t_L$ )	217°C 60-150 seconds
Peak/Classification Temperature ( $T_p$ )	260°C +/- 5°C
Time within 5°C of actual Peak Temperature ( $t_p$ )	20-40 seconds
Ramp-Down Rate	6°C / second max.
Time 25°C to Peak Temperature	8 minutes max.

Empfohlenes Reflow-Lötprofil:

*Recommended Reflow-Soldering profile:*



T