

7091

SMT Buchsenleiste RM 1,00 mm - 2-reihig - BH 2,25 mm

SMT Female Header - Pitch 1,00 mm - Double Row - Profile 2,25 mm

Technische Daten / Technical Data:

Isolierkörper	Thermoplastischer Kunststoff, nach UL94V0
Insulator	Thermoplastic, rated UL94V0
Kontaktmaterial	Kontakt CuZn 30
Contact Material	Contact CuZn 30
Kontaktfläche	lt. Oberflächenoptionen, über Ni (1,3-2,5 µm)
Contact Surface	acc. to options (see below), over Ni (1,3-2,5 µm)
Lötbarkeit	IEC512-12A
Solderability	IEC512-12A
Durchgangswiderstand	≤ 20 mOhm
Contact Resistance	≤ 20 mOhm
Isolationswiderstand	> 10 ⁹ Ohm
Insulation Resistance	> 10 ⁹ Ohm
Spannungsfestigkeit	500 V _{AC}
Test Voltage	500 V _{AC}
Nennstrom	1 A
Current Rating	1 A
Temperaturbereich	-40°C...+105°C
Temperature Range	-40°C...+105°C
Verarbeitung	Reflow-Lötverfahren; weitere Informationen in Kapitel T
Processing	Reflow-Soldering, further informations in chapter T

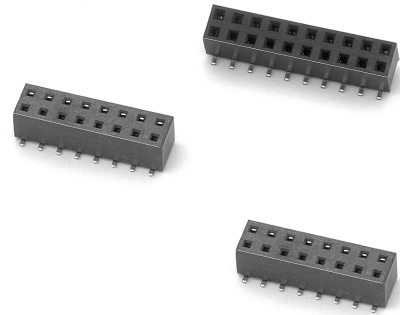

© W+P PRODUCTS

Passende Stiftleisten Serie:
Mates with Pin Headers Series:
721 / 7059 / 6210

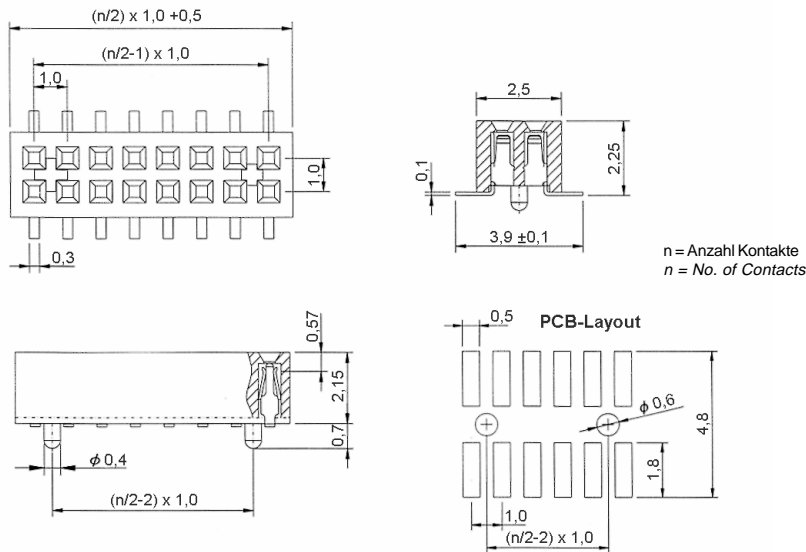

Series	Contacts*	Profile	Plating*	Packing*
7091	100	30	00	ST
	008-100-pol. zweireihig double row	30 = BH 2,25 mm; Eingang oben Profile 2,25 mm; top entry	00 = vergoldet gold plated 50 = verzinnt tin plated	00 ST

Lieferformen / Packing Options:

00 = Schüttgut ohne PP-Pad / bulk good w/o PP-Pad

ST = verpackt in Stangen / packed in tubes

PPST ** = in Stangen mit PP-Pad / in tubes w/ PP-Pad

PPTR ** = mit PP-Pad, Tape & Reel Verpackung / Tape & Reel Packing w/ PP-Pad

(** auf Anfrage / upon request)

(* Bestellbeispiel - Bitte durch Ihre Spezifikationen ersetzen.)

* Order example - To be replaced by your specifications.)

TEL.: +49 5223 98507-0
FAX : +49 5223 98507-50

W+P PRODUCTS

E-MAIL: sales@wpro.com
INTERNET: www.wpro.com

Informationen zum Reflow-Lötverfahren

Reflow-Soldering Informations

Reflow-Lötverfahren Reflow-Soldering

Bauteile sollten gemäß folgendem Temperatur-Profil in Anlehnung an die IPC/JEDEC J-STD-020C für bleifreies Lötten im Reflowverfahren verarbeitet werden (Maximalwerte):

Profil Eigenschaft	Bleifreies Lötten
Durchschnitts-Ramp-Up Rate ($T_{s_{max}}$ to T_p)	3 °C / Sek. Max.
Vorheizen - Temperatur Min ($T_{s_{min}}$) - Temperatur Max ($T_{s_{max}}$) - Zeit ($t_{s_{min}}$ auf $t_{s_{max}}$)	150°C 200°C 60-180 Sekunden
Verbleiben oberhalb: - Temperatur (T_L) - Zeit (t_L)	217°C 60-150 Sekunden
Peak/Klassifizierung Temperatur (T_p)	260°C +/- 5°C
Zeit innerhalb von 5°C um die Peak-Temperatur (t_p)	20-40 Sekunden
Ramp-Down Rate	6°C / Sekunde max.
Zeit von 25°C bis zur Peak-Temperatur	8 Minuten max.

© W+P PRODUCTS

Items should be soldered according to IPC/JEDEC J-STD-020C temperature-profile for leadfree reflow-soldering (maximum values):

Profile Feature	PB-Free assembly
Average Ramp-Up Rate ($T_{s_{max}}$ to T_p)	3 °C / second max.
Preheat - Temperature Min ($T_{s_{min}}$) - Temperature Max ($T_{s_{max}}$) - Time ($t_{s_{min}}$ to $t_{s_{max}}$)	150°C 200°C 60-180 seconds
Time maintained above: - Temperature (T_L) - Time (t_L)	217°C 60-150 seconds
Peak/Classification Temperature (T_p)	260°C +/- 5°C
Time within 5°C of actual Peak Temperature (t_p)	20-40 seconds
Ramp-Down Rate	6°C / second max.
Time 25°C to Peak Temperature	8 minutes max.

Empfohlenes Reflow-Lötprofil:

Recommended Reflow-Soldering profile:



T