

SMT Buchsenleisten RM 1,27 mm - 1-/2-reihig - Präzisionskontakt

SMT Female Header Strips Pitch 1,27 mm - Single and Double Row - Screw Machined Contacts

Technische Daten / Technical Data:

Isolierkörper <i>Insulator</i>	Thermoplastischer Kunststoff, nach UL94V0 <i>Thermoplastic, rated UL94V0</i>
Kontaktmaterial	Hülse: Messing gedreht Feder: 3 Lamellen-Clip, Beryllium-Kupfer
<i>Contact Material</i>	<i>Sleeve: Screw Machined Brass</i> <i>Clip: 3 Finger-Clip, Beryllium-Copper</i>
Kontaktoberfläche <i>Contact Surface</i>	lt. Oberflächenoptionen, über Ni (1,3-2,5 µm) <i>acc. to options (see below), over Ni (1,3-2,5 µm)</i>
Lötbarkeit <i>Solderability</i>	IEC512-12A
Durchgangswiderstand <i>Contact Resistance</i>	≤ 10 mOhm
Isolationswiderstand <i>Insulation Resistance</i>	> 10 ¹⁰ Ohm
Spannungsfestigkeit <i>Test Voltage</i>	1000 V _{RMS}
Nennstrom <i>Current Rating</i>	1 A
Temperaturbereich <i>Temperature Range</i>	-55°C...+125°C
Verarbeitung <i>Processing</i>	Reflow-Lötverfahren; weitere Informationen in Kapitel T <i>Reflow-Soldering, further informations in chapter T</i>



© W+P PRODUCTS

B

Passende Stiftleisten Serie:
Mates with Pin Headers Series:
7061

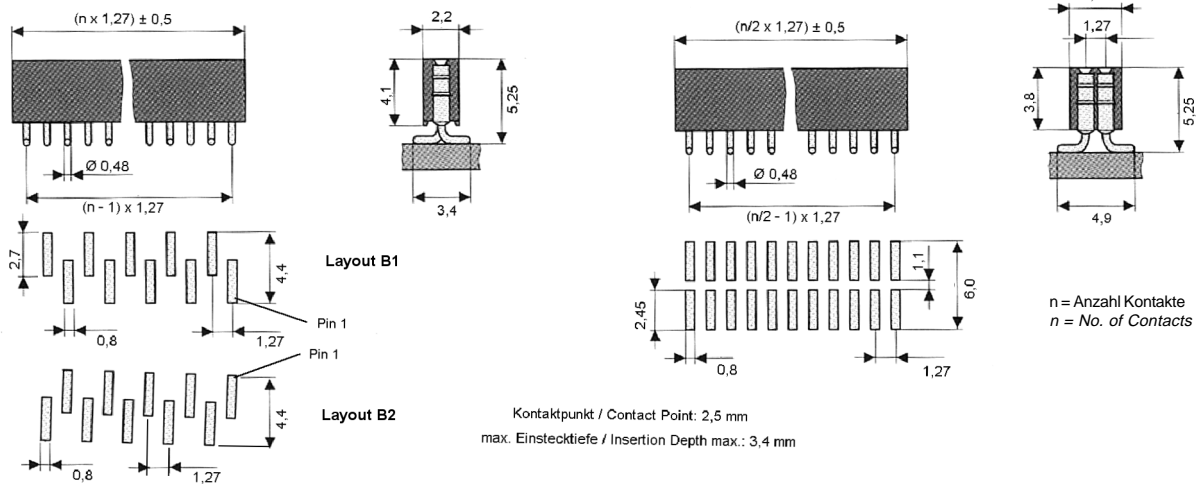

Series	Contacts*	Rows*	Sleeve Plating	Clip Plating*	Packing*
1551	020	2	50	30	00
	003-050-pol. einreihig <i>single row</i> 004-100-pol. zweireihig <i>double row</i>	1 = einreihig B1 <i>single row B1</i> 2 = einreihig B2 <i>single row B2</i> 3 = zweireihig <i>double row</i>	50 = Hülse verzinkt <i>sleeve tin plated</i>	10 = Feder 0,25 µm Gold <i>0,25 µm gold plated</i> 30 = Feder 0,75 µm Gold <i>0,75 µm gold plated</i>	00 ST PPST PPTR

Lieferformen / Packing Options:
00 = Schüttgut ohne PP-Pad / *bulk goods w/o PP-Pad*
ST = verpackt in Stangen / *packed in tubes*
PPST = in Stangen mit PP-Pad / *in tubes w/ PP-Pad*
PPTR ** = mit PP-Pad, Tape & Reel Verpackung / *Tape & Reel Packing w/ PP-Pad*
 (** auf Anfrage / *upon request*)

(* Bestellbeispiel - Bitte durch Ihre Spezifikationen ersetzen.
* Order example - To be replaced by your specifications.)

Informationen zum Reflow-Lötverfahren

Reflow-Soldering Informations

Reflow-Lötverfahren Reflow-Soldering

Bauteile sollten gemäß folgendem Temperatur-Profil in Anlehnung an die IPC/JEDEC J-STD-020C für bleifreies Löten im Reflowverfahren verarbeitet werden (Maximalwerte):

Profil Eigenschaft	Bleifreies Löten
Durchschnitts-Ramp-Up Rate ($T_{s_{max}}$ to T_p)	3 °C / Sek. Max.
Vorheizen - Temperatur Min ($T_{s_{min}}$) - Temperatur Max ($T_{s_{max}}$) - Zeit ($t_{s_{min}}$ auf $t_{s_{max}}$)	150°C 200°C 60-180 Sekunden
Verbleiben oberhalb: - Temperatur (T_L) - Zeit (t_L)	217°C 60-150 Sekunden
Peak/Klassifizierung Temperatur (T_p)	260°C +/- 5°C
Zeit innerhalb von 5°C um die Peak-Temperatur (t_p)	20-40 Sekunden
Ramp-Down Rate	6°C / Sekunde max.
Zeit von 25°C bis zur Peak-Temperatur	8 Minuten max.

© W+P PRODUCTS

Items should be soldered according to IPC/JEDEC J-STD-020C temperature-profile for leadfree reflow-soldering (maximum values):

Profile Feature	PB-Free assembly
Average Ramp-Up Rate ($T_{s_{max}}$ to T_p)	3 °C / second max.
Preheat - Temperature Min ($T_{s_{min}}$) - Temperature Max ($T_{s_{max}}$) - Time ($t_{s_{min}}$ to $t_{s_{max}}$)	150°C 200°C 60-180 seconds
Time maintained above: - Temperature (T_L) - Time (t_L)	217°C 60-150 seconds
Peak/Classification Temperature (T_p)	260°C +/- 5°C
Time within 5°C of actual Peak Temperature (t_p)	20-40 seconds
Ramp-Down Rate	6°C / second max.
Time 25°C to Peak Temperature	8 minutes max.

Empfohlenes Reflow-Lötprofil:

Recommended Reflow-Soldering profile:



T