

## SMT-Buchsenleisten RM 2,00mm, stehend, 1-reihig - BH 4,3mm, durchsteckbar SMT Female Headers, 2.00mm Pitch, Vertical, Single Row - 4.3mm Profile, Pass Through

### Technische Daten / Technical Data

Isolierkörper	Thermoplastischer Kunststoff, nach UL94 V-0
Insulator	Thermoplastic, rated UL94 V-0
Kontaktmaterial	Kupferlegierung
Contact Material	Copper alloy
Kontaktoberfläche	Lt. Oberflächenoptionen, über Ni (1,3 ... 2,5µm)
Contact Surface	Acc. to options (see below), over Ni (1.3 ... 2.5µm)
Lötbarkeit	IEC 60512-12A
Solderability	IEC 60512-12A
Durchgangswiderstand	< 20mΩ
Contact Resistance	< 20mΩ
Isolationswiderstand	> 1000MΩ
Insulation Resistance	> 1000MΩ
Spannungsfestigkeit	500V <sub>AC</sub>
Test Voltage	500V <sub>AC</sub>
Nennstrom	1A
Current Rating	1A
Temperaturbereich	-40°C ... +125°C
Temperature Range	-40°C ... +125°C
Verarbeitung	Reflow-Lötverfahren
Processing	Reflow soldering

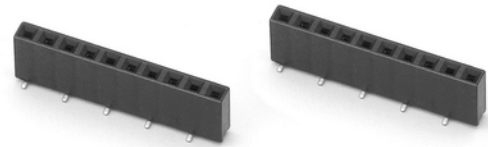

© W+P PRODUCTS

Doppelfederkontakte für Vierkantstifte 0,50mm.  
Dual beam contacts accept 0.50mm square pins.

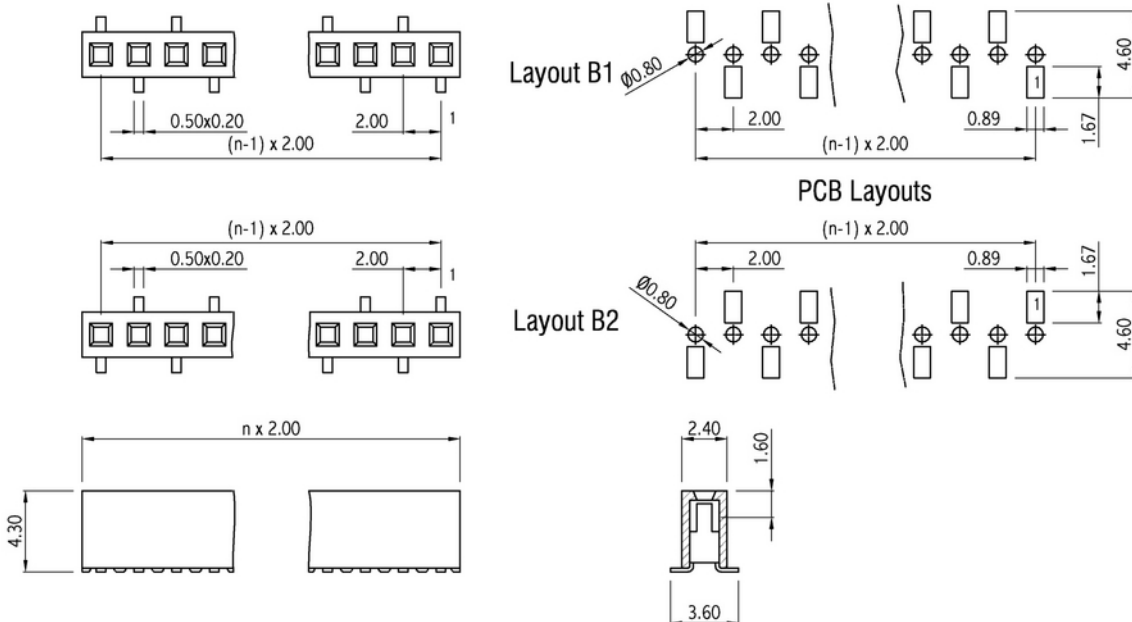

Series	Contacts*	Type*	Plating*	Packaging*
<b>7451</b>	<b>036</b> 004-040	<b>1</b> 1 Layout B1 2 Layout B2	<b>50</b> 00 Vergoldet Gold plated 50 Verzinkt Tin plated 60 Sel. Au/Sn Duplex plating	<b>PPST</b> ST PPST PPTR

\* Dies ist ein **Bestellbeispiel** - bitte durch Ihre Spezifikationen ersetzen.  
\* This is an **order example** - please replace by your specifications.

TEL +49 5223 98507-0  
FAX +49 5223 98507-50

**Lieferformen / Packaging Options:**  
**ST** In Stangen ohne Pick&Place-Pad / In tubes w/o Pick&Place-Pad  
**PPST** In Stangen mit P&P-Pad / In tubes with P&P-Pad  
**PPTR** Tape & Reel mit P&P-Pad / Tape & Reel with P&P-Pad

# Informationen zum Reflow-Lötverfahren

## Reflow Soldering Information

### Reflow-Lötempfehlung

#### Reflow Soldering Recommendation

Die Bauteile sollten gemäß folgendem Temperatur-Profil in Anlehnung an die IPC/JEDEC J-STD-020C für bleifreies Löten im Reflow-Verfahren verarbeitet werden (Maximalwerte).

Profileigenschaft	Kennwert
Temperatur Minimum $T_{Smin}$	150°C
Temperatur Maximum $T_{Smax}$	200°C
Dauer $T_{Smin} - T_{Smax}$	60-180s
Temperatur Lötbereich $T_L$	217°C
Verweildauer oberhalb $T_L$	60-180s
Ramp-Up Rate $T_{Smax} - T_P$	max. 3°C / s
Höchsttemperatur $T_P$	260°C ±5
Dauer Höchsttemperatur	20-40s
Ramp-Down Rate $T_{Pmax} - T_{Smin}$	6°C / s
Dauer 25°C - Höchsttemperatur $T_P$	Max. 8 min

Items should be soldered according to IPC/JEDEC J-STD-020C temperature profile for leadfree reflow soldering (maximum values).

Profile Feature	Key Values
Minimum Temperature $T_{Smin}$	150°C
Maximum Temperatur $T_{Smax}$	200°C
Duration $T_{Smin} - T_{Smax}$	60-180s
Soldering Range Temperature $T_L$	217°C
Duration above $T_L$	60-180s
Ramp-Up Rate $T_{Smax} - T_P$	max. 3°C / s
Peak Temperature $T_P$	260°C ±5
Duration Peak Temperature	20-40s
Ramp-Down Rate $T_{Pmax} - T_{Smin}$	6°C / s
Duration 25°C - Peak Temp. $T_P$	Max. 8min

