

Wannenstiftleisten mit Verriegelung RM 1,27mm, gerade/gewinkelt Box Headers with Latches, 1.27mm Pitch, Straight/Right-Angled

Technische Daten / Technical Data

Isolierkörper	Thermoplastischer Kunststoff, nach UL94 V-0
Insulator	Thermoplastic, rated UL94 V-0
Kontaktmaterial	Kupferlegierung
Contact Material	Copper alloy
Kontaktfläche	Lt. Oberflächenoptionen, über Ni
Contact Surface	Acc. to options (see below), over Ni
Lötbarkeit	IEC 60512-12A
Solderability	IEC 60512-12A
Durchgangswiderstand	< 20mΩ
Contact Resistance	< 20mΩ
Isolationswiderstand	> 1000MΩ
Insulation Resistance	> 1000MΩ
Spannungsfestigkeit	300V _{AC}
Test Voltage	300V _{AC}
Nennstrom	1A
Current Rating	1A
Temperaturbereich	-40°C ... +105°C
Temperature Range	-40°C ... +105°C
Verarbeitung	Wellen- oder Reflow-Lötverfahren
Processing	Wave or reflow soldering



© W+P PRODUCTS

Passender Gegenstecker Serie:
Mates with Connector Series:
376

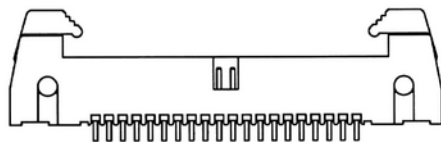
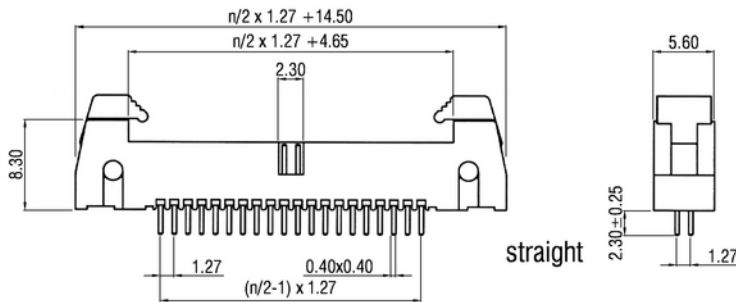

Rcm. PCB Layout

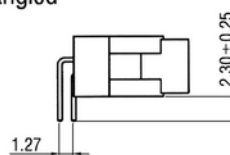
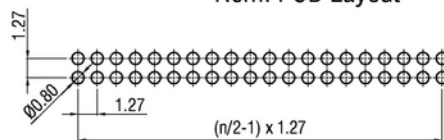

Series	Contacts*	Type*	Plating*
337	12	1	00
	06 10 12 14 16 20 26 30 34 40 44 50 60 68 80	1 Gerade Straight 2 Gewinkelt Right-angled	00 Vergoldet Gold plated

* Dies ist ein **Bestellbeispiel** -
bitte durch Ihre Spezifikationen ersetzen.
* This is an **order example** -
please replace by your specifications.

Informationen zum Reflow-Lötverfahren

Reflow Soldering Information

Reflow-Lötempfehlung

Reflow Soldering Recommendation

Die Bauteile sollten gemäß folgendem Temperatur-Profil in Anlehnung an die IPC/JEDEC J-STD-020C für bleifreies Löten im Reflow-Verfahren verarbeitet werden (Maximalwerte).

Profileigenschaft	Kennwert
Temperatur Minimum T_{Smin}	150°C
Temperatur Maximum T_{Smax}	200°C
Dauer $T_{Smin} - T_{Smax}$	60-180s
Temperatur Lötbereich T_L	217°C
Verweildauer oberhalb T_L	60-180s
Ramp-Up Rate $T_{Smax} - T_P$	max. 3°C / s
Höchsttemperatur T_P	260°C ±5
Dauer Höchsttemperatur	20-40s
Ramp-Down Rate $T_{Pmax} - T_{Smin}$	6°C / s
Dauer 25°C - Höchsttemperatur T_P	Max. 8 min

Items should be soldered according to IPC/JEDEC J-STD-020C temperature profile for leadfree reflow soldering (maximum values).

Profile Feature	Key Values
Minimum Temperature T_{Smin}	150°C
Maximum Temperatur T_{Smax}	200°C
Duration $T_{Smin} - T_{Smax}$	60-180s
Soldering Range Temperature T_L	217°C
Duration above T_L	60-180s
Ramp-Up Rate $T_{Smax} - T_P$	max. 3°C / s
Peak Temperature T_P	260°C ±5
Duration Peak Temperature	20-40s
Ramp-Down Rate $T_{Pmax} - T_{Smin}$	6°C / s
Duration 25°C - Peak Temp. T_P	Max. 8min

