

Technische Daten / Technical Data

Gehäuse	Stahl vernickelt, verzinkt
Shell	Steel, tin coated over nickel
Isolierkörper	Thermoplastischer Kunststoff, nach UL94 V-0
Insulator	Thermoplastic, rated UL94 V-0
Kontaktmaterial	Kupferlegierung
Contact Material	Copper alloy
Kontaktfläche	Gold über Nickel
Contact Surface	Gold over nickel
Durchgangswiderstand	< 20mΩ
Contact Resistance	< 20mΩ
Isolationswiderstand	> 1000MΩ
Insulation Resistance	> 1000MΩ
Spannungsfestigkeit	1kV _{AC}
Test Voltage	1kV _{AC}
Nennstrom	5A
Current Rating	5A
Temperaturbereich	-55°C ... +125°C
Temperature Range	-55°C ... +125°C
Güteklasse	GK 3, min. 50 Steckzyklen, andere GK auf Anfrage
Quality Class	Quality class 3, min. 50 cycles, more quality options on request

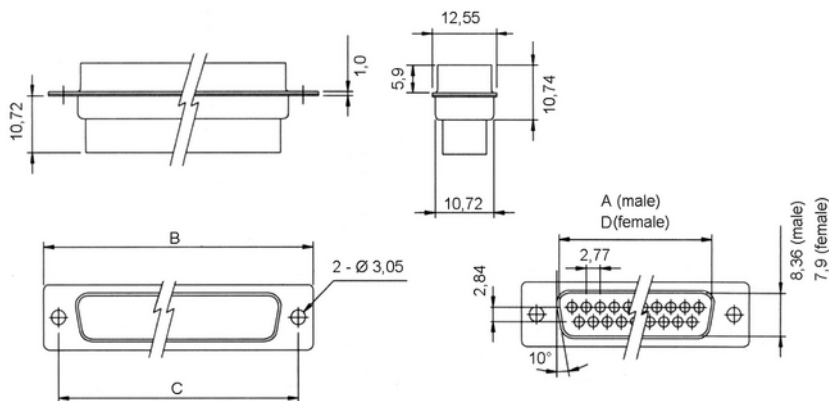

© W+P PRODUCTS



n	A±0.25	B±0.25	C±0.25	D±0.25
09	16.92	30.81	25.00	16.32
15	25.25	39.17	33.32	24.68
25	38.96	53.05	47.04	38.39
37	55.42	69.36	63.50	54.82

Series	Contacts*	Terminal*	Mounting*
115	09	1	0
Gehäuse Housing	09/15/25/37	1 Stift Male 2 Buchse Female	0-CL Lt. Tech. Info. See Tech. Info.

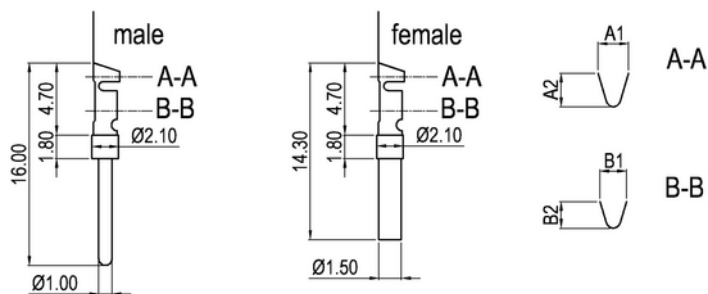

A1±0.05	A2±0.05	B1±0.05	B2±0.05
2.14	2.26	1.75	1.54

Series	AWG	Terminal*	Plating	Packing
115	24	1	3	3
Kontakte Contacts	24 AWG 24-26	1 Stift Male 2 Buchse Female	3 GK 3 min. 50 Steckzyklen Quality Class 3: min. 50 cycles	3 Auf Rolle On reel

* Dies ist ein **Bestellbeispiel** - bitte durch Ihre Spezifikationen ersetzen.
* This is an **order example** - please replace by your specifications.

Befestigungsoptionen Mounting Options

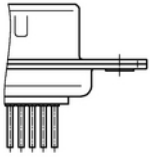

0 Durchgangsloch 3,05mm
3.05mm Through Hole

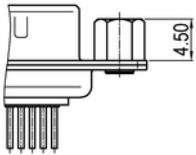

B1 Gewindeniet UNC 4-40
UNC 4-40 Thread Rivet

B2 Gewindeniet M3
M3 Thread Rivet

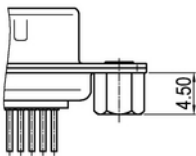

1 Gewindeniet UNC 4-40
UNC 4-40 Thread Rivet

2 Gewindeniet M3
M3 Thread Rivet

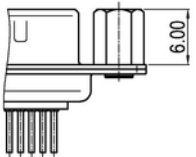

3 Gewindebolzen UNC 4-40
UNC 4-40 Thread Bolt

4 Gewindeniet M3
M3 Thread Rivet

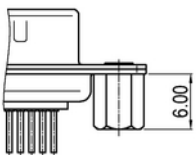

5 Gewindebolzen UNC 4-40
UNC 4-40 Thread Bolt

6 Gewindebolzen M3
M3 Thread Bolt

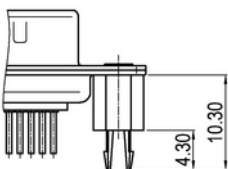

BL Board Lock mit UNC 4-40 Gewinde
Board Lock with UNC 4-40 Thread

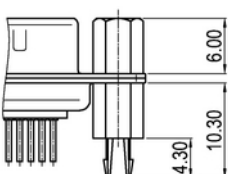

CL Combi-Lock mit UNC 4-40 Gewinde
Combi Lock with UNC 4-40 Thread