

SMT-Buchsenleisten RM 2,54mm, stehend, 1-reihig - BH 5,0mm, durchsteckbar SMT Female Headers, 2.54mm Pitch, Vertical, Single Row - 5.0mm Profile, Pass Through

Technische Daten / Technical Data

Isolierkörper	Thermoplastischer Kunststoff, nach UL94 V-0
Insulator	Thermoplastic, rated UL94 V-0
Kontaktmaterial	Phosphorbronze
Contact Material	Phosphor bronze
Kontaktoberfläche	Lt. Oberflächenoptionen, über Ni (1,3 ... 2,5µm)
Contact Surface	Acc. to options (see below), over Ni (1.3 ... 2.5µm)
Lötbarkeit	IEC 60512-12A
Solderability	IEC 60512-12A
Durchgangswiderstand	< 20mΩ
Contact Resistance	< 20mΩ
Isolationswiderstand	> 1000MΩ
Insulation Resistance	> 1000MΩ
Spannungsfestigkeit	500V _{AC}
Test Voltage	500V _{AC}
Nennstrom	3A
Current Rating	3A
Temperaturbereich	-40°C ... +105°C
Temperature Range	-40°C ... +105°C
Verarbeitung	Reflow-Lötverfahren
Processing	Reflow soldering

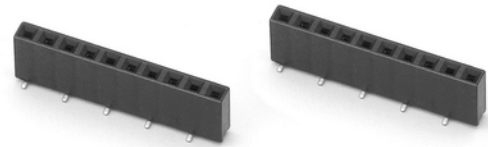

© W+P PRODUCTS

Doppelfederkontakte für Vierkantstifte 0,635mm.
Dual beam contacts accept 0.635mm square pins.

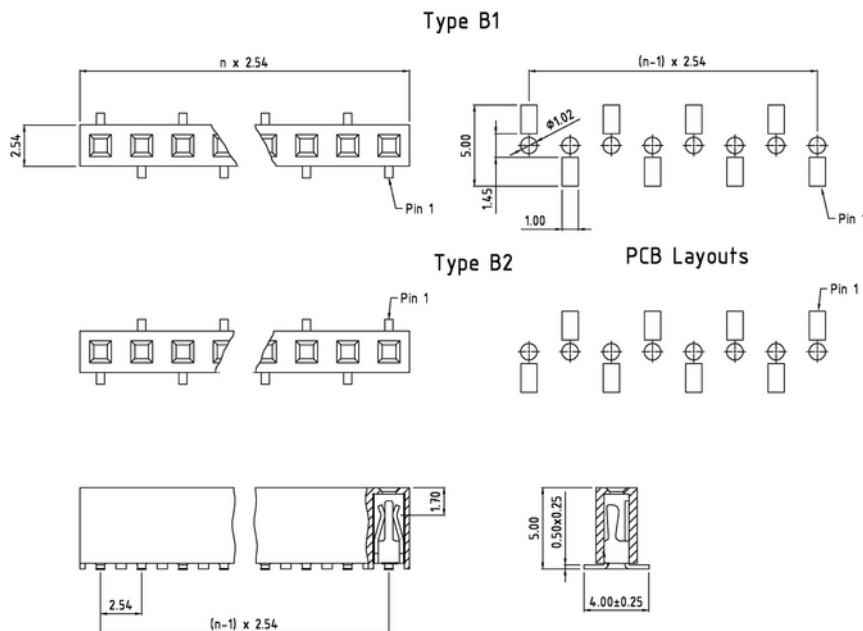

Series	Contacts*	Type*	Plating*	Packaging*
3498	10 02-40 Einreihig Single row	2 1 Layout B1 2 Layout B2	50 00 Vergoldet Gold plated 50 Verzinkt Tin plated 60 Sel. Au/Sn Duplex plating	PPTR ST PPST PPTR

Lieferformen / Packaging Options:

ST In Stangen ohne Pick&Place-Pad / In tubes w/o Pick&Place-Pad
PPST In Stangen mit P&P-Pad / In tubes with P&P-Pad
PPTR Tape & Reel mit P&P-Pad / Tape & Reel with P&P-Pad

* Dies ist ein **Bestellbeispiel** - bitte durch Ihre Spezifikationen ersetzen.
 * This is an **order example** - please replace by your specifications.

TEL +49 5223 98507-0
 FAX +49 5223 98507-50

W+P PRODUCTS

E-MAIL sales@wpro.com
 WEBSITE www.wpro.com

Informationen zum Reflow-Lötverfahren

Reflow Soldering Information

Reflow-Lötempfehlung

Reflow Soldering Recommendation

Die Bauteile sollten gemäß folgendem Temperatur-Profil in Anlehnung an die IPC/JEDEC J-STD-020C für bleifreies Löten im Reflow-Verfahren verarbeitet werden (Maximalwerte).

Profileigenschaft	Kennwert
Temperatur Minimum T_{Smin}	150°C
Temperatur Maximum T_{Smax}	200°C
Dauer $T_{Smin} - T_{Smax}$	60-180s
Temperatur Lötbereich T_L	217°C
Verweildauer oberhalb T_L	60-180s
Ramp-Up Rate $T_{Smax} - T_P$	max. 3°C / s
Höchsttemperatur T_P	260°C ±5
Dauer Höchsttemperatur	20-40s
Ramp-Down Rate $T_{Pmax} - T_{Smin}$	6°C / s
Dauer 25°C - Höchsttemperatur T_P	Max. 8 min

Items should be soldered according to IPC/JEDEC J-STD-020C temperature profile for leadfree reflow soldering (maximum values).

Profile Feature	Key Values
Minimum Temperature T_{Smin}	150°C
Maximum Temperatur T_{Smax}	200°C
Duration $T_{Smin} - T_{Smax}$	60-180s
Soldering Range Temperature T_L	217°C
Duration above T_L	60-180s
Ramp-Up Rate $T_{Smax} - T_P$	max. 3°C / s
Peak Temperature T_P	260°C ±5
Duration Peak Temperature	20-40s
Ramp-Down Rate $T_{Pmax} - T_{Smin}$	6°C / s
Duration 25°C - Peak Temp. T_P	Max. 8min

